

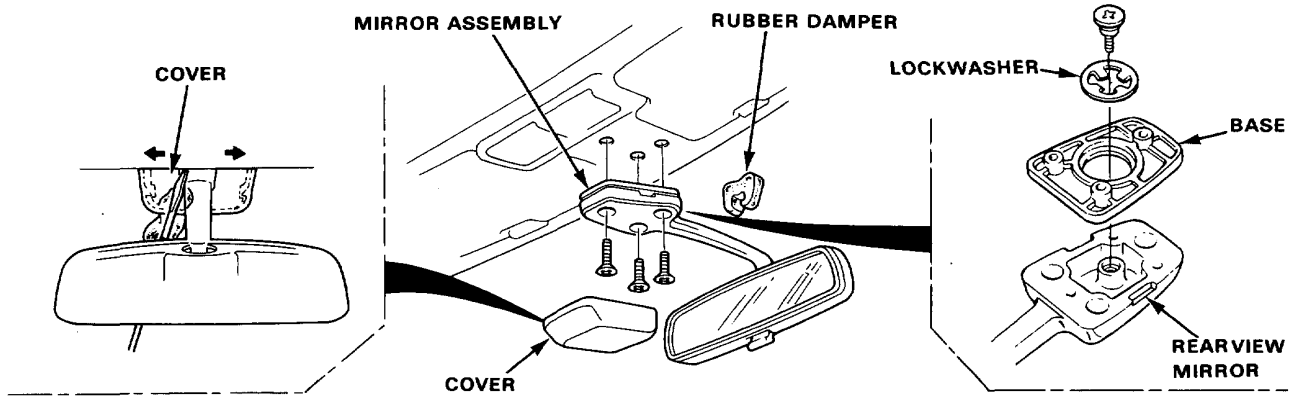

# Rearview Mirror / Console

## Rearview Mirror Replacement

1. Remove the rubber damper.
2. Pry the cover off using the end of a flat tip screwdriver.
3. Remove the 3 mounting screws from the mirror base, then remove the mirror assembly.
4. Remove the base from the bracket by removing the screw.



## Console Replacement

Disassemble in numbered sequence.

4WS:

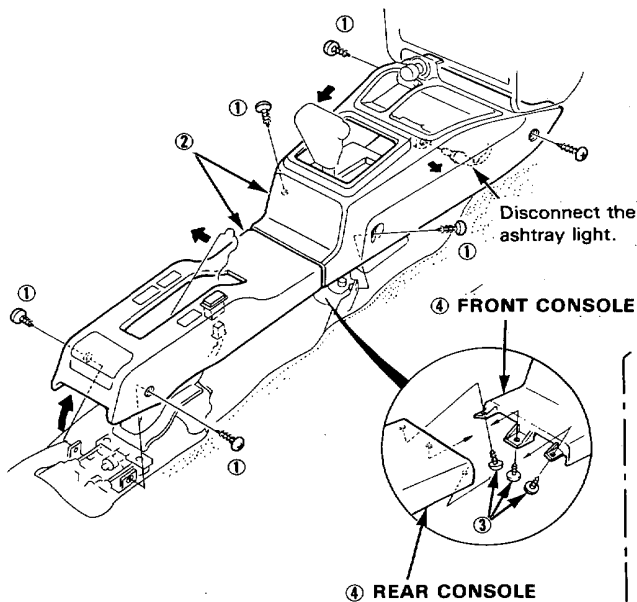

2WS:

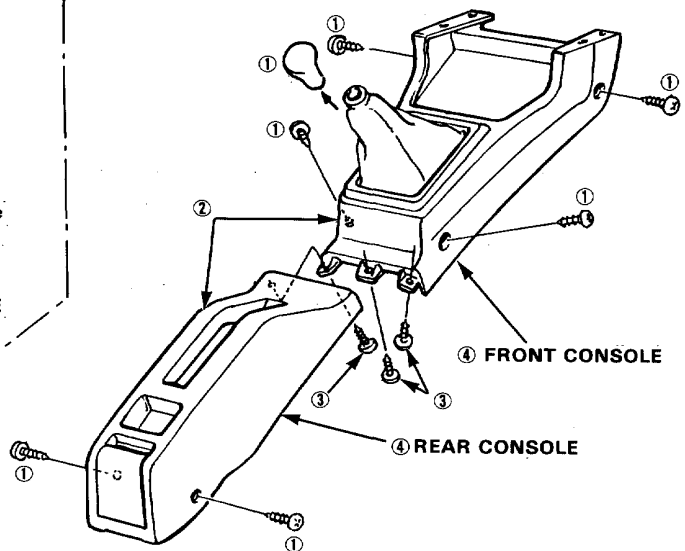

### NOTE:

- Remove the front and rear consoles as an assembly.
- Lift up the parking brake lever.
- For manual transmission models, remove the shift lever knob.

# Carpet/Door Sill Moldings

## Replacement

1. Remove:
  - Front seats and rear seat cushion.
  - Front seat belt lower anchor bolts (page 14-46).
  - Center console.
  - Right and left kick panels.
  - Door sill moldings.
  - Opener cover.
  - Footrest.
2. Pry out the clips at the rear edge and under the dashboard, peel off the tape.
3. Cut the ④ area first, then pull back the carpet as shown.
4. Remove the carpet by sliding it rearward.

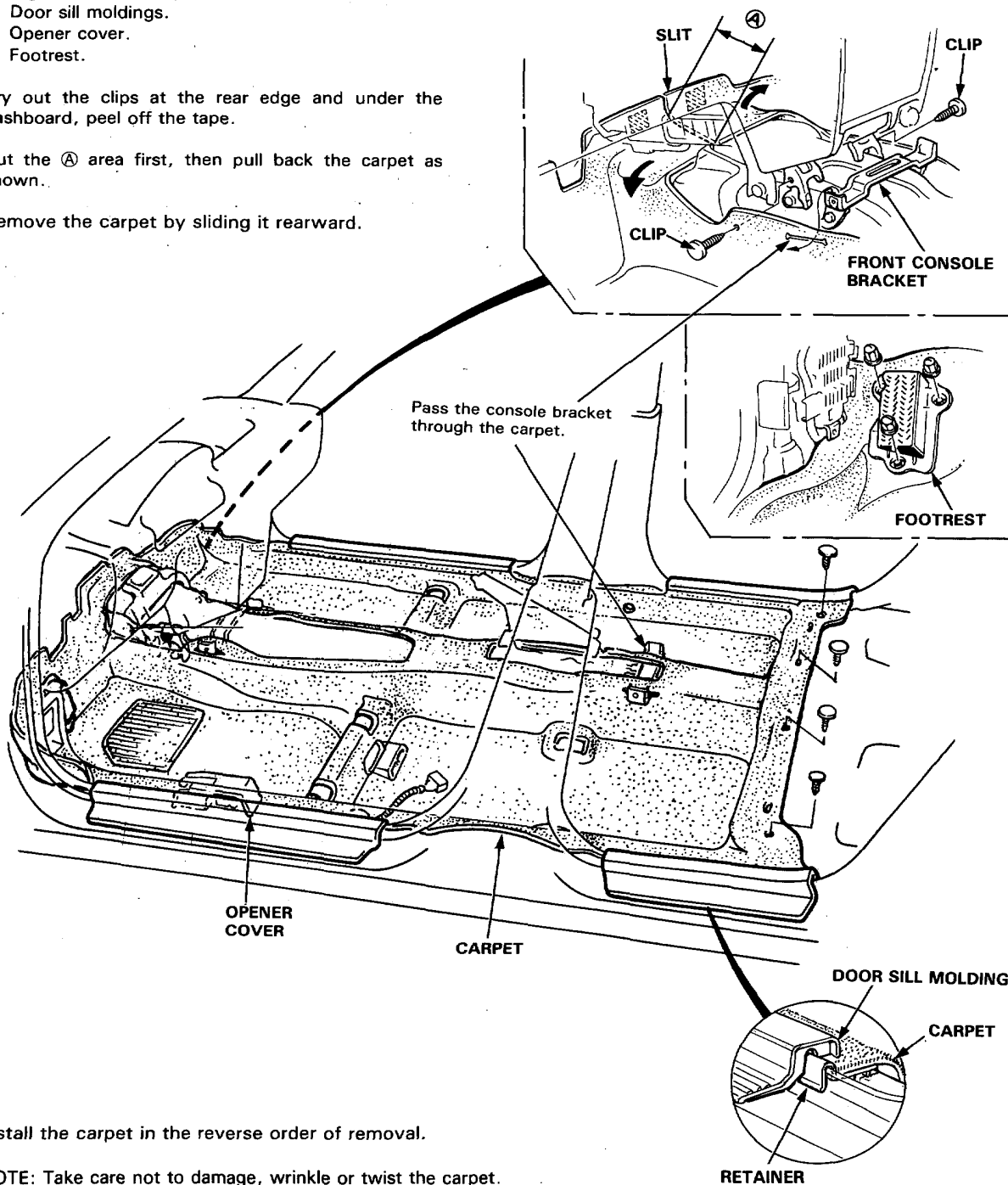

5. Install the carpet in the reverse order of removal.

NOTE: Take care not to damage, wrinkle or twist the carpet.



# Dashboard

## Component Removal/Installation

NOTE: Take care not to scratch or score the dashboard and instrument panel.

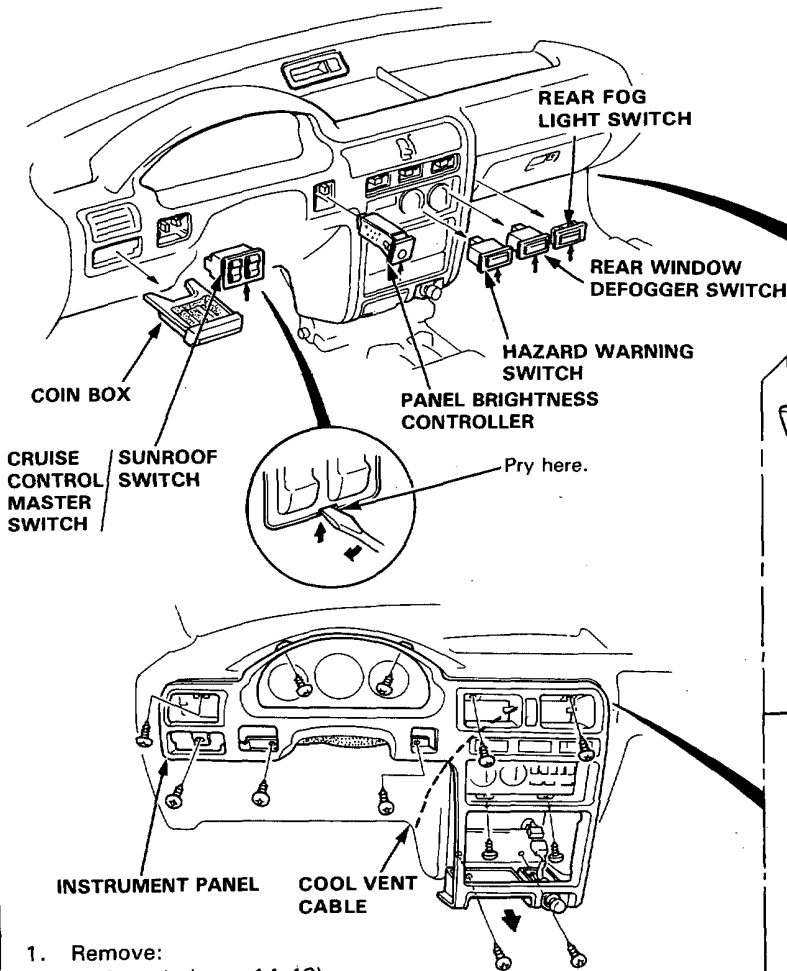

**CLOCK**  
Remove the clock from left side.

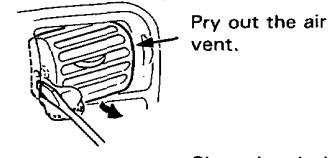
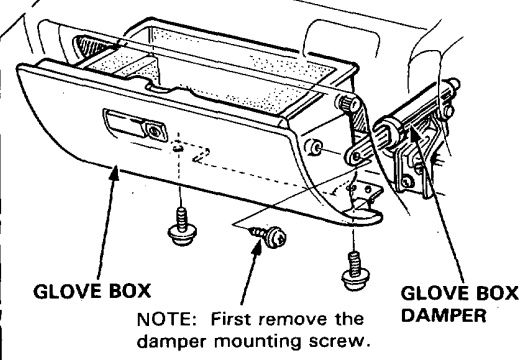
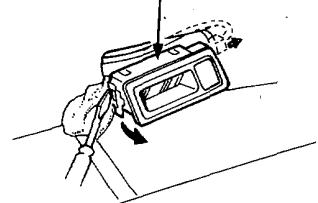

Close the air damper.

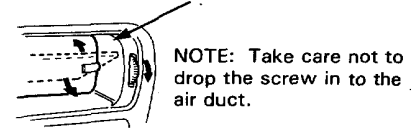

- Remove:
  - Console (page 14-49).
  - Ashtray and ashtray holder
  - Stereo cassette/radio
  - Coin box, cruise control master switch • sunroof switch and panel brightness controller.
  - Side and Center air vents.
  - Disconnect the cool vent cable (See section 15).
- Remove the 12 mounting screws and disconnect the connectors.
- Carefully pull out the instrument panel from the dashboard.

**STEREO CASSETTE/RADIO**  
Remove the console, ashtray and ashtray holder. Loosen the 2 screws from underneath and disconnect the wire harness (antenna lead), then pull the stereo cassette/radio out half-way and separate the pocket.

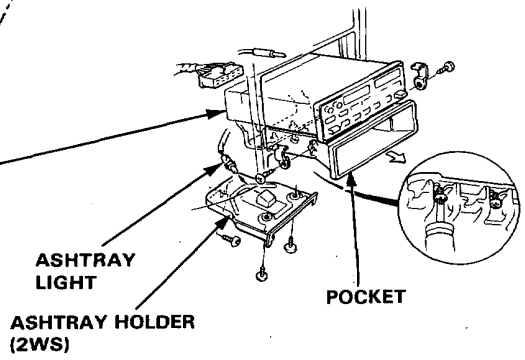

# Dashboard

## Replacement

NOTE: Take care not to scratch or score the dashboard and use protective tape on the bottom of the front pillar trim.

1. To remove the dashboard, first slide the seats back fully.
2. Remove the console (page 14-49).
3. Remove the steering column (See section 11).
4. Disconnect the dashboard wire harness from the connectors and fuse box.
5. Remove the carpet clips and disconnect the antenna lead.
6. Disconnect the heater control cable and function control cable or cool vent cable (See section 15).
7. Remove the caps on both side and clock.
8. Remove the 7 dashboard mounting bolts.
9. Lift and remove the dashboard.

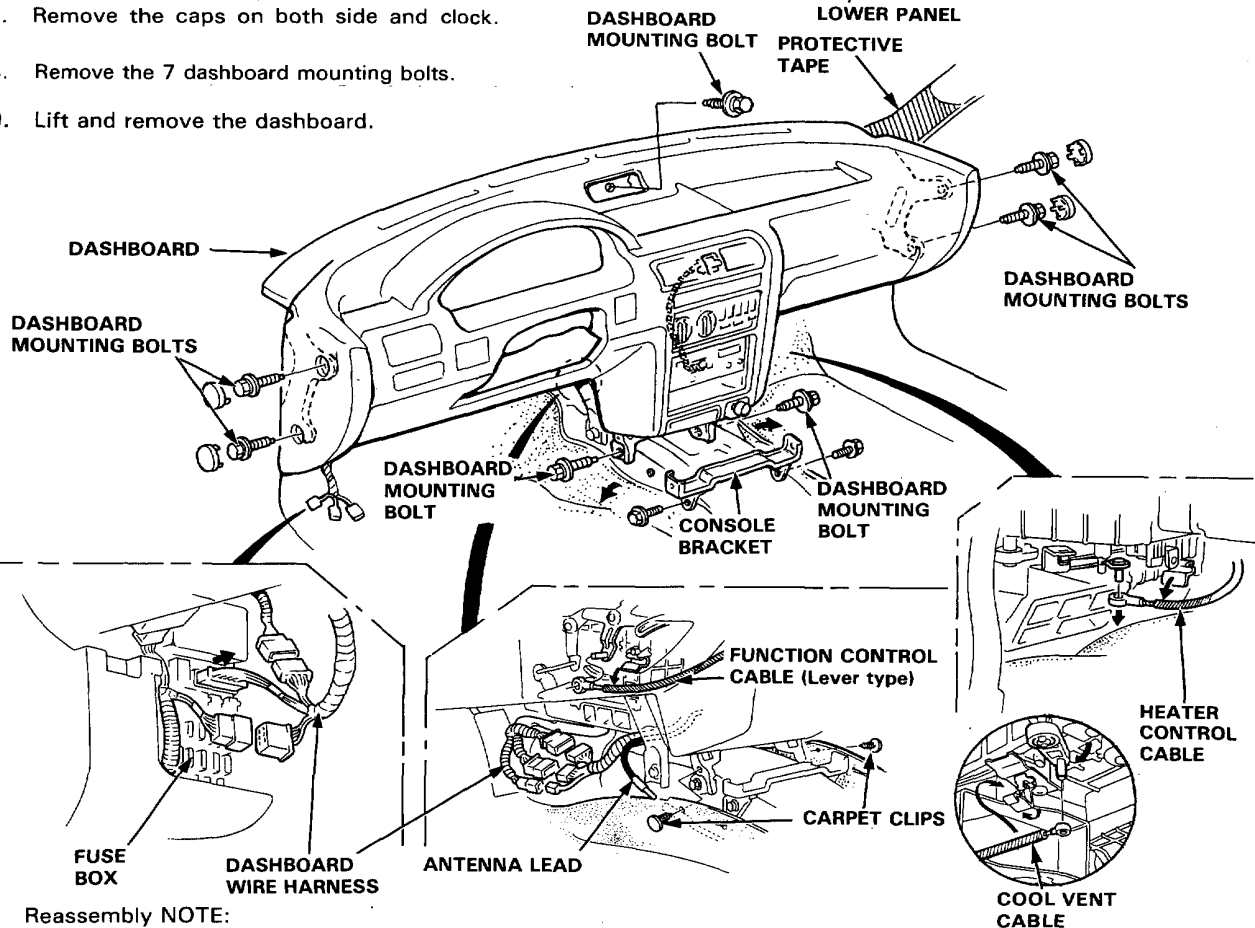
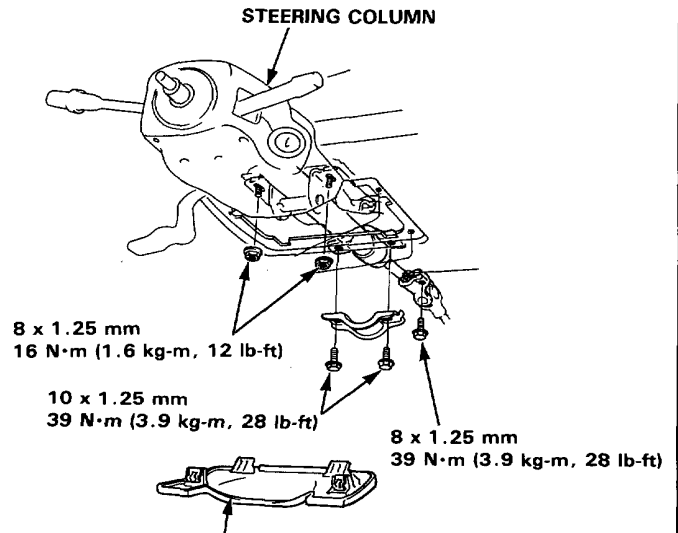

### Reassembly NOTE:

- Make sure the dashboard fits onto the body correctly.
- Before tightening the dashboard bolts, make sure the dashboard wires are not pinched, and that the dashboard is not interfering with the heater control and function cables.